

## VA-7450 series Reversible Valve actuator

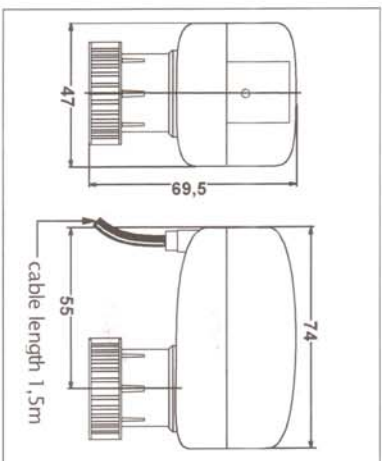

Figure 1: Dimensions (in mm)

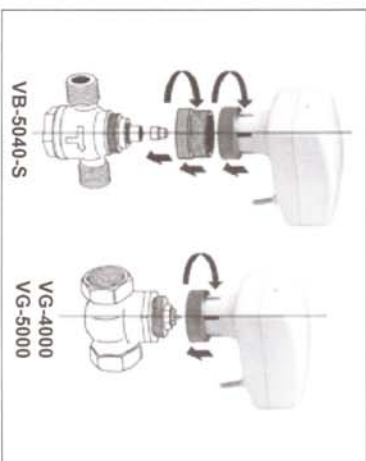

Figure 2: Mounting

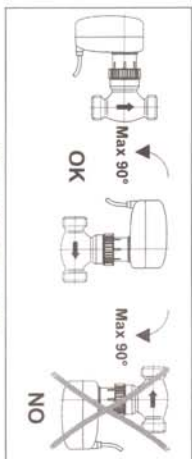

Figure 2b: Mounting

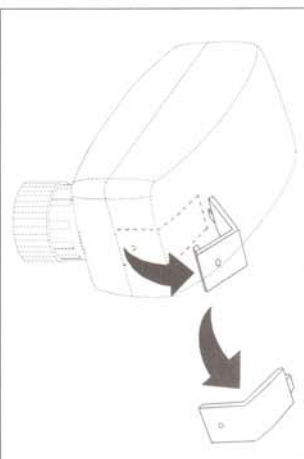

Figure 3: Cover

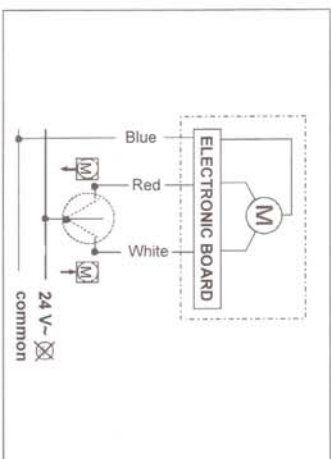

Figure 4: Wiring Diagrams (Incremental model)

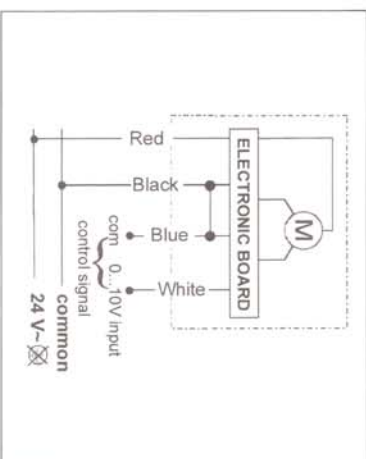

Figure 4b: Wiring Diagrams (Proportional model)

## ENGLISH

**READ THIS INSTRUCTION SHEET CAREFULLY BEFORE  
 INSTALLING AND SAVE FOR FUTURE USE**

### Dimensions (Figure 1)

**Application**  
 The series VA-7450 actuators are designed to fit Johnson Controls VGS000 and VB-5040-S valves.

### Mounting (Figure 2 and 2b)

#### Cover (Figure 3)

Cover for jumper selection (removable only on VA-7452-9001)

**IMPORTANT:** the actuator stem is in completely up position from the factory. If the actuator is powered when not mounted on the valve, be sure to return the spindle to completely up position before mounting onto the valve.

### Wiring Diagrams (Figure 4 e Figure 4b)

- Before mounting, wiring or adjusting the actuator, make sure that the power supply has been disconnected to avoid possible harm to material or person.
- Make sure that the line power supply is in accordance with the power supply specified on the actuator.
- All wiring should conform to local codes and must be carried out by authorised personnel only.
- When using multi-stranded wire apply a cable ferrule to the cable end.

**Note:** These controls are intended to control equipment under normal operating conditions. Where failure or malfunction of the controls could lead to an abnormal operating condition that could cause personal injury or damage to the equipment or other property, other devices (limit or safety controls) or systems (alarm or supervisory systems) intended to warn of or protect against failure or malfunction of the controls must be incorporated into and maintained as part of the control system.

### Adjustments (jumper settings) of proportional models

VA-7452-1001 has FIXED settings (the jumpers are NOT accessible)

VA-7452-9001 is fully configurable

| Function                        | Jumper No. | VA-7452-9001 (adjustable)                     |  | VA-7452-1001 (fixed settings)                 |
|---------------------------------|------------|---|--|---|
|                                 |            | Factory setting                               | Alternative setting  |   |
| Anti-sticking                   | 1          | enabled                                       | <input type="checkbox"/> disabled                                    | not active                                    |
| Input control signal            | 2          | 0...10V                                       | <input type="checkbox"/> 5...10V <input type="checkbox"/> 0...5V     | 0...10V                                       |
| Combined flow characteristic *) | 4          | almost linear (VG4000 and VGS000)             | <input type="checkbox"/> almost equal percentage (VG4000 and VGS000) | linear (VG4000 and VGS000)                    |
| Action                          | 5          | Direct (DA)                                   | <input type="checkbox"/> Reverse (RA)                                | Direct (DA)                                   |
| Valve port type                 | 6          | 2-way PTO (NC) and 3-way Normally Closed port | <input type="checkbox"/> 2-way PTO (NO) valve bodies                 | 2-way PTO (NC) and 3-way Normally Closed port |

\*) In combination with VB-5040-S valve bodies, Jumper 4 must be set to linear. On VGS000 series with Kvs 0.25 and 0.4 combined flow characteristic, is always "quick opening" independent from jumper setting.

### Led indication

|  |                        |
|--|------------------------|
| <input checked="" type="checkbox"/> ON | power line present     |
| <input type="checkbox"/> OFF           | power line not present |
| <input type="checkbox"/> Blinking      | the motor is running   |

After 2 minutes the motor is running, an internal timer switches off the motor. When the signal is 0% or 100%, the timer switches on the motor every 2 hours for 2 minutes, in the signal direction.

### Anti-sticking cycle (only VA-7452 models)

Every 24 hours, the actuator runs one complete cycle up and down and returns to the control position.

### Check out procedure

Before leaving the installation observe at least three complete operating cycles to be sure that all components are functioning correctly. If not, contact your supplier.

### Autozero cycle (only on VA-7452 models)

Each time the power is switched on, the actuator performs one complete stroke time down and after that it reaches the control position.

### Repair and replacement

Field repair is not possible. If the actuator is not working properly and all wiring is correct, the actuator should be replaced. Please check with your nearest supplier.

This is how the jumpers are positioned on the board:

